

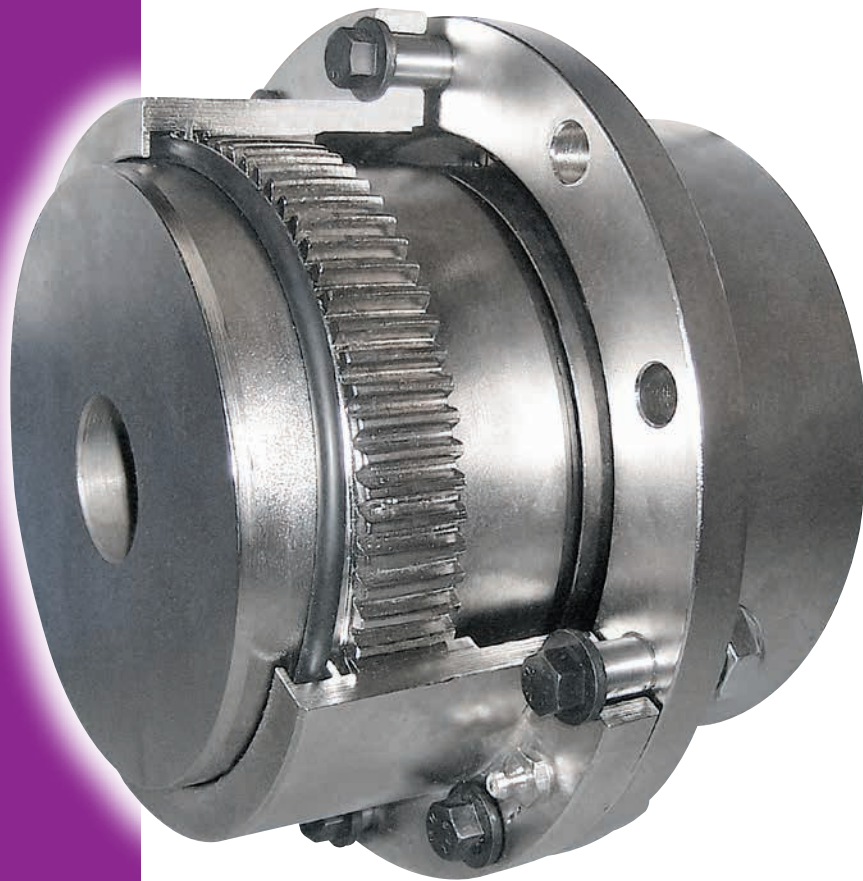

WESTCAR s.r.l.

ROTOGEAR

Giunto a Denti
Gear Coupling



Tipo RE - *Type RE*





ROTOFLUID



ROTOFLEXI



ROTOFLUID CA



ROTOFLEXI-DFRN



ROTOMECC



BARREL COUPLINGS



DRUM BRAKES BD



STEELFLEX



DRUM BRAKES CD



ROTOELASTIC

Discover more

Products



*ON REQUEST,
ATEX CERTIFIED PRODUCTS
CAN BE SUPPLIED.*



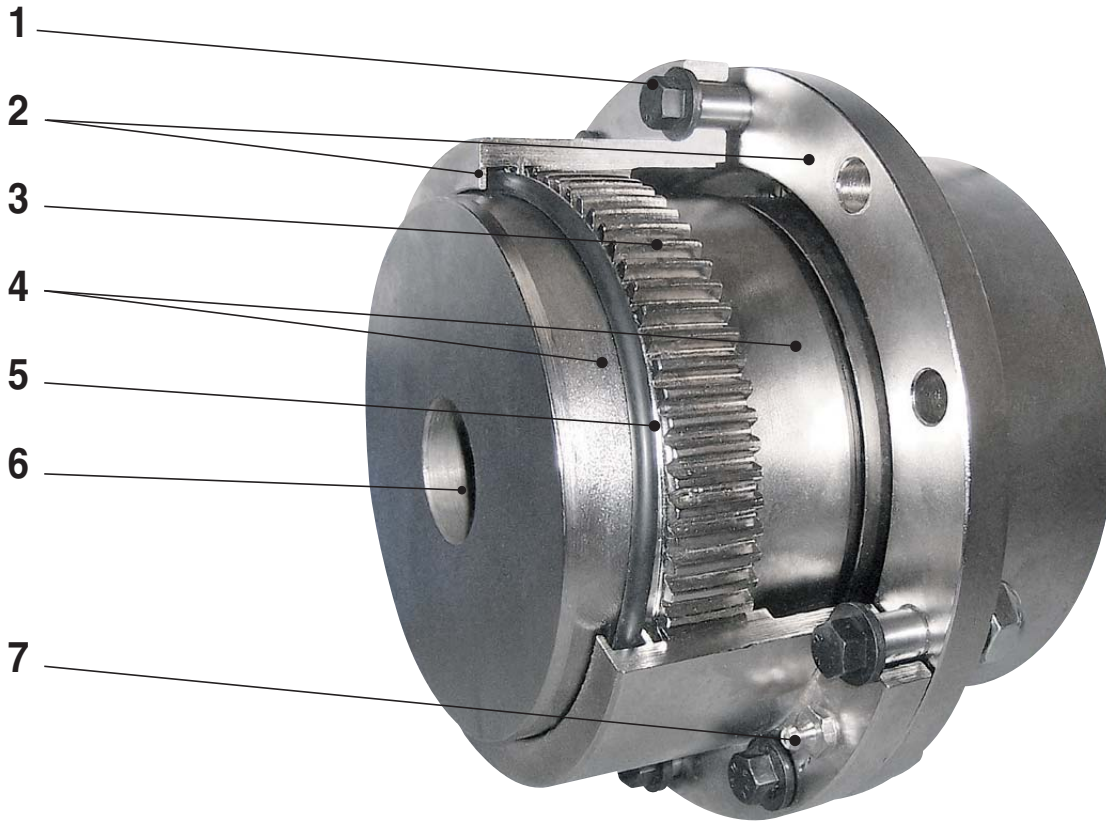

- 1 Viti Calibrate in acciaio speciale
- 2 Campane dentate, ricavate da pezzo unico
- 3 Dentatura bombata
- 4 Mozzi dentati
- 5 O-Rings
- 6 Mozzi lavorati con foro e cava a richiesta
- 7 Due ingrassatori per ogni campana

- 1 Calibrate special-steel screws
- 2 One-piece sleeve with internal straight teeth
- 3 Crowned tothing
- 4 Hub teeth
- 5 O-Rings
- 6 Machined bore and keyway upon request
- 7 Two lubrication plugs are mounted on each half sleeve

<p>I Giunti a Denti ROTOGEAR rappresentano il collegamento più affidabile ed economico per alberi di comandi industriali di media e grande potenza</p>	<p><i>ROTOGEAR couplings are the most reliable and economic solution for connecting shafts in medium and heavy industry drives.</i></p>
<p>Ideali per la compensazione di disallineamenti angolari, radiali e combinati, senza apprezzabile perdita di potenza. Assorbono eventuali dilatazioni e movimenti assiali.</p>	<p><i>Ideal for the compensation of angular, radial and combined misalignments, without appreciable loss of power. They absorb any expansions and axial movements.</i></p>
<p>La dentatura bombata garantisce una maggiore area di contatto, un numero maggiore di denti in presa, una migliore distribuzione del carico con un gioco minimo.</p>	<p><i>Crowned tothing assures a larger contact area and more teeth constantly in contact, an optimum load distribution with a minimum backlash</i></p>
<p>I giunti della serie "RE" sono progettati per compensare un disallineamento statico di 1° per ogni ingranamento.</p>	<p><i>The "RE" series couplings are designed to compensate for a 1° static misalignment every gear.</i></p>

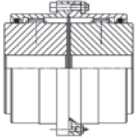
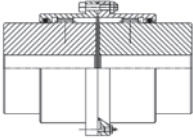
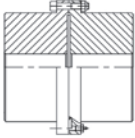
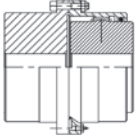
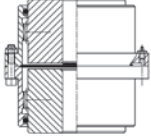
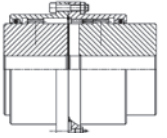
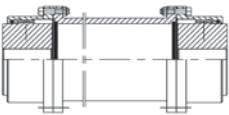
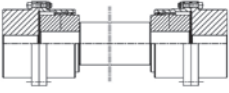
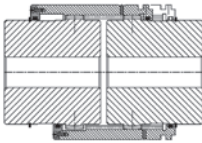
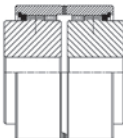
Tipo di Giunto <i>Coupling Type</i>	Serie <i>Series</i>	Descrizione <i>Description</i>	Pagina <i>Page</i>
	RE	Giunto con mozzi standard <i>Coupling with standard hubs</i>	9
	RE UU	Giunto con mozzi lunghi <i>Coupling with long hubs</i>	10
	RE FOO	Giunto rigido <i>Rigid coupling</i>	11
	RE FO	Giunto semirigido <i>Half rigid coupling</i>	12
	RE V	Giunto verticale <i>Vertical coupling</i>	13
	RE FT	Giunto scorrevole <i>Sliding coupling</i>	14
	RE D	Giunto con spaziatore <i>Coupling with spacer</i>	15
	RE B	Giunto con albero flottante <i>Coupling with floating shaft</i>	16
	RE DH.MN RE DH.PN	Giunto disinnestabile <i>Disengaging Coupling</i>	17
	RE M	Giunto a manicotto "M" serie <i>Sleeve coupling "M" serie</i>	18

WESTCAR ROTOGEAR RE..	MAINA ..A	FACHI IF..	ESCO FST	FAL G..	KOP-FLEX H	AJAX 6901	LOVEJOY F	AMERIDRIVES F
40	0	3	45	-	1	1	1	101
55	1	4	60	15	1½	1,5	1½	101½
70	2	5,5	75	20	2	2	2	102
85	3	7	95	25	2½	2,5	2½	102½
100	4	8	110	30	3	3	3	103
120	5	9,5	130	35	3½	3,5	3½	103½
140	6	11	155	40	4	4	4	104
160	7	12	175	45	4½	4,5	4½	104½
180	8	14	195	50	5	5	5	105
200	9	15	215	55	5½	5,5	5½	105½
220	10	16,5	240	60	6	6	6	106
250	11	19	275	70	7	7	7	107

Nella scelta del Giunto a Denti si devono considerare diversi fattori, procedere come di seguito:

- A** - Eseguire una selezione preliminare del giunto.
- B** - Controllare che i diametri di foratura siano compatibili a quelli indicati nelle tabelle
- C** - Selezionare un fattore di servizio idoneo, seguendo la relativa tabella.

To select the Gear Coupling several factors must be considered, proceed as follows:

- A** - Make a preliminary coupling selection.
- B** - Check that the drilling diameters are compatible with those indicated in the tables
- C** - Select a suitable service factor, following the relative table.

Tabella Fattori di Servizio Safety Factor Table		Motori Elettrici Turbine a Gas o Vapore	Macchine a Vapore Turbine ad acqua	Macchine Alternative Motori Elettrici con partenze frequenti
		<i>Electric motor Gas or Steam Turbine</i>	<i>Steam Engine Water Turbine</i>	<i>Alternative Machine Electric motor with frequent starting</i>
COPPIA COSTANTE: Pompe centrifughe, alternatori, piccoli convettori	COSTANT TORQUE: <i>Centrifugal pump, alternator, light conveyors</i>	1,0	1,25	1,75
COPPIA POCO FLUTTUANTE: Macchine utensili, pompe a vite, compressori a vite, compressori ad anello liquido	SLIGHT FLUCTUATION TORQUE: <i>Machine tools, screw compressor, screw pumps, liquid ring compressors</i>	1,25	1,5	2
COPPIA FLUTTUANTE: Pompe alternative, miscelatori a bassa viscosità, gru	FLUCTUATION TORQUE: <i>Reciprocating pumps, low viscosity mixer, cranes</i>	1,5	2	2,5
COPPIA CON ALTE FLUTTUAZIONI: Presse rotanti, compressori alternativi, miscelatori ad alta viscosità	HEAVY FLUCTUATION TORQUE: <i>Rotary presses, reciprocating compressor, high viscosity mixer</i>	2	2,5	3

La tabella riportata dà una guida approssimativa ai fattori di servizio per applicazioni generali; per dati più specifici si raccomanda di consultare le normative AGMA 922-A96 o norme similari, oppure consultare il nostro ufficio tecnico.

Il giunto a denti sopporta una coppia di spunto/transitoria pari a 2 volte la coppia nominale; se tale coppia è maggiore di 2 applicare un idoneo SF o consultare l'ufficio tecnico.

D - calcolare il fattore **KD**, in funzione al disallineamento angolare (°) ricavabile dal grafico

The table gives a rough guide to safety factors for general applications. For specific figures see AGMA 922-A96 or similar norms or refer to our technical department.

The elastic coupling listed in the catalogue bears a starting torque equivalent to 2 nominal torque; if this torque is higher than 2 add a suitable "SF" or asks to technical dept.

D - calculate the **KD** factor, according to the angular misalignment (°) obtained from the graph

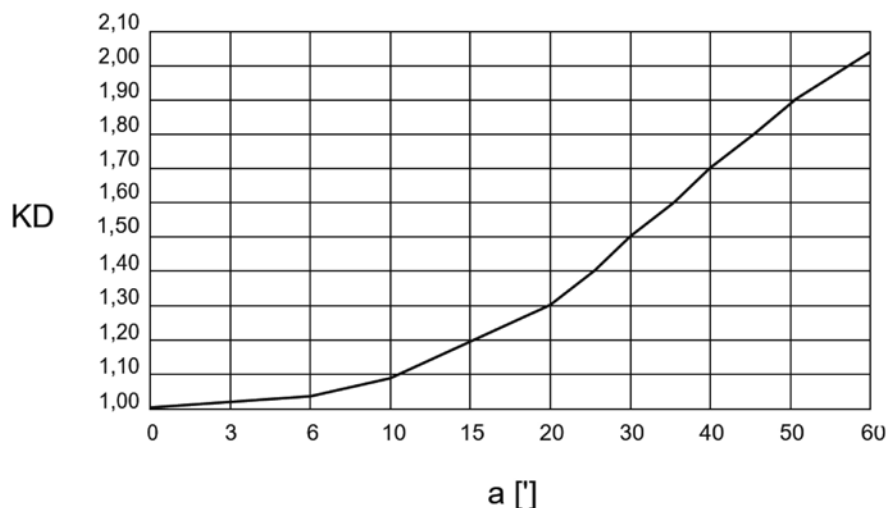

E- Selezionare il giunto considerando i parametri di lavoro, utilizzando la formula sottostante.

E - Make the coupling selection considering the working condition, using the below formula

$$T = \frac{P \times SF \times KD \times 9550}{n \times 1000} \quad (\text{kNm})$$

P = Potenza in Kw	Power in Kw
SF = Fattore di servizio	Safety factor
KD = Fattore di disallineamento angolare	Angular misalignment factor
9550 = Rapporto fisso	Ratio
n = Velocità	Speed

F- Confrontare il valore ottenuto T con la coppia nominale T_n, nelle rispettive tabelle, se T è maggiore, passare alla taglia successiva

F - Compare the obtained value T with the nominal torque T_n, in the respective tables, if T is greater, go to the next size.

G- Controllare che il numero di giri "n" sia inferiore o uguale al numero di giri massimo della grandezza del giunto selezionato (vedi tabella), moltiplicato per il fattore di velocità KV, in funzione al disallineamento di lavoro α (°) riportato nella tabella sottostante.

G - Check that the number of revolutions "n" is less or equal to the maximum number of revolutions of the selected coupling size (see table), multiplied by the speed factor KV, according to the work misalignment α (°) shown in chart below.

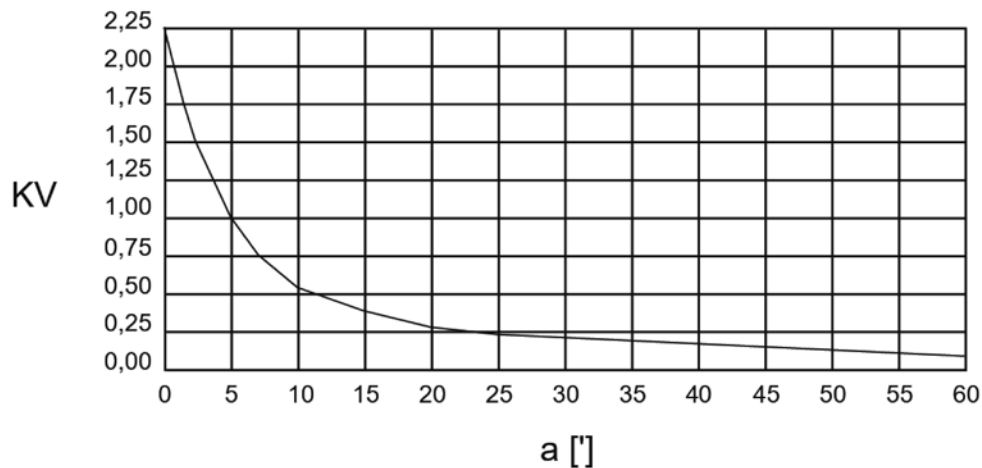

Raccomandazioni:

Evitare il contatto di sostanze acide o oli, anche dispersi nell'ambiente per evitare reazioni non previste negli elastomeri installati.

 Nelle zone a rischio esplosione:
Aumentare il SF, del 20% rispetto ai valori dati.
Prestare particolare attenzione alla temperatura ambiente e al calore trasmesso dagli alberi (max. 90°C).

Remarks:

Avoid contact of acidic substances or oils, also dispersed in the environment to avoid unforeseen reactions in the installed elastomers.

 In hazardous zone:
Increase the SF as 20% to the given date.
Pay attention to the ambient temperature and to the heat conduct by the shafts (max. 90°C).

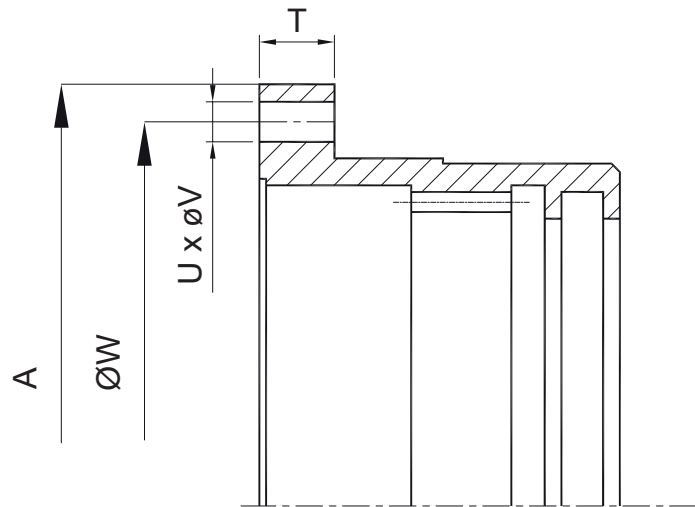

Dimensioni Dimension		40	55	70	85	100	120	140	160	180	200	220	250
A	mm	111	142	168	200	225	265	300	330	370	406	438	505
T	mm	12	10	10	13	13	22	22	22	24	25	25	28
u	Quantità Quantity	6	8	10	10	12	12	14	14	14	14	14	16
V H8	mm	8	10	10	12	12	16	16	16	18	22	22	24
W	mm	96	122	148	178	203	236	270	300	335	368	400	460

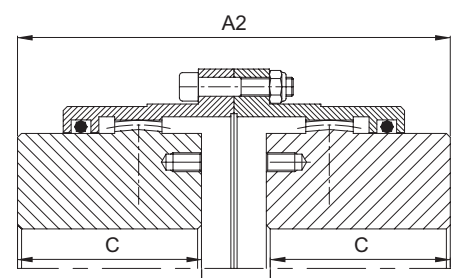
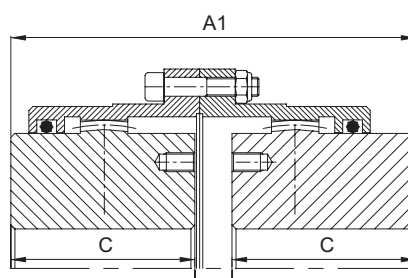
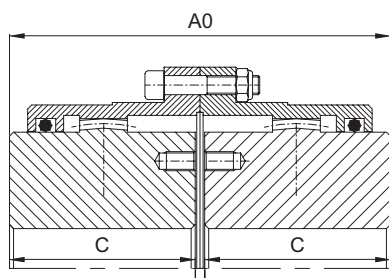

Posizione mozzi Hubs position		40	55	70	85	100	120	140	160	180	200	220	250
A0	mm	89	103	127	157	185	216	246	278	308	358	388	450
A1	mm	103	108	138	164	204	237	272	307	350	403	438	512
A2	mm	127	113	149	171	223	258	298	336	392	448	488	574
e	mm	43	50	62	76	90	105	120	135	150	175	190	220
G	mm	3	3	3	5	5	6	6	8	8	8	8	10
G1	mm	5	8	14	12	24	27	32	37	50	53	58	72
G2	mm	7	13	25	19	43	48	58	66	92	98	108	134

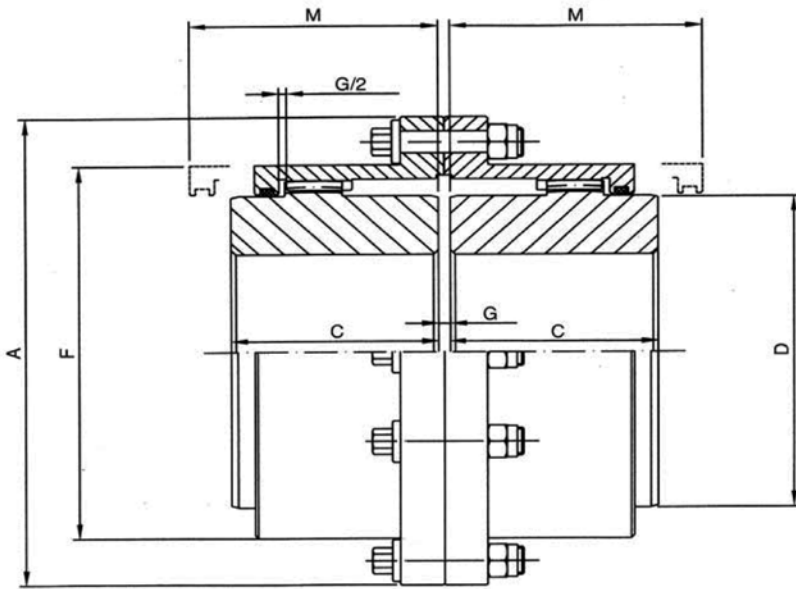

RE...

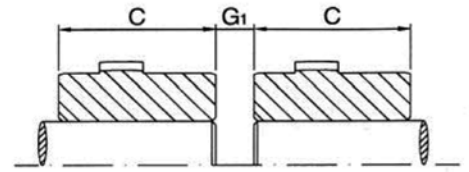

RE...R

Con un mozzo rovesciato
One reverse hub

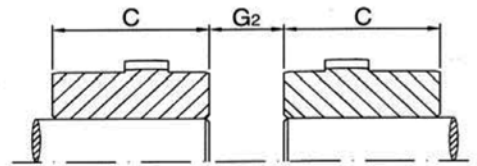

RE...RR

Con due mozzi rovesciati
Two reverse hubs

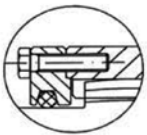

Flangia porta guarnizione dalla taglia 280
Seal flange from size 280

Taglia Size	Coppia Torque		Velocità Speed	Fori Bores		Dimensioni Dimensions								Peso Weight	Grasso Grease	Inerzia Inertia
	kNm		Rpm	mm		mm								kG (2)	kG	Kgm ² (2)
	Tn	Tmax	max	min	max	A	C	F	D	M(1)	G	G1	G2			
40	1,7	4,1	5990	12	50	111	43	82,5	69	58	3	5	7	4	0,08	0,005
55	2,7	6,2	4610	18	60	142	50	104,5	85	68	3	8	13	8	0,09	0,012
70	5,5	12	4130	28	75	168	62	130,5	107	87	3	14	25	13	0,15	0,032
85	8,5	21	3980	40	95	200	76	158,5	133	95	5	12	19	26	0,25	0,084
100	13,5	34	3850	50	110	225	90	183,5	152	120	5	24	43	37	0,45	0,162
120	22	54	3700	60	130	265	105	211,5	178	130	6	27	48	59	0,70	0,375
140	34	83	3200	70	155	300	120	245,5	209	135	6	32	58	91	0,90	0,728
160	43	99	2900	85	170	330	135	275	234	155	8	37	66	123	1,54	1,225
180	68	156	2550	95	190	370	150	307	254	195	8	50	92	170	2,30	2,105
200	82	195	2320	110	210	406	175	335	279	220	8	53	98	234	3,20	3,401
220	150	348	2100	120	230	438	190	367	305	236	8	58	108	295	3,90	5,052
250	195	579	1800	120	280	505	220	423	355	273	10	72	134	455	6,10	10,32
280	275	550	1200	150	325	580	250	495	400	-	12	-	-	685	6,50	20,60
320	381	762	980	170	370	630	275	545	450	-	12	-	-	920	7,20	33,50
360	492	984	900	190	400	700	305	589	490	-	12	-	-	1210	8,50	53,30
400	658	1316	800	210	430	760	330	649	550	-	12	-	-	1590	11,40	83,50
450	835	1670	700	240	475	825	355	714	580	-	12	-	-	2060	12,50	128,40

(1) Distanza minima necessaria per l'allineamento - *Minimum clearance required for alignment*

(2) I valori si riferiscono a mozzi senza foro - *Data with unbored hubs*

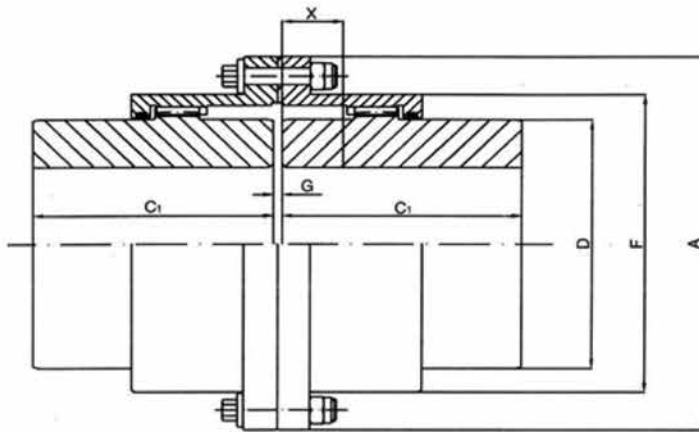

RE...UU

Flangia porta guarnizione dalla taglia 280
Seal flange from size 280

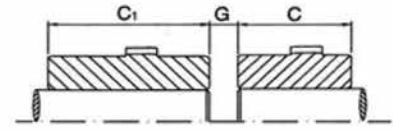

RE...U

Con un mozzo lungo e uno standard
With one long and one standard hub

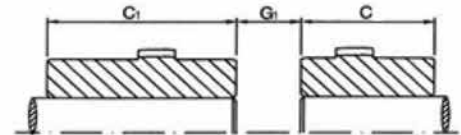

RE...UR

Con un mozzo lungo e uno standard rovesciato
With one long and one standard reverse hub

Taglia Size	Coppia Torque		Velocità Speed	Fori Bores		Dimensioni Dimensions								Peso Weight	Grasso Grease	Inerzia Inertia
	kNm		Rpm	mm		mm								kG (1)	kG	Kgm ² (1)
	Tn	Tmax	max	min	max	A	C1	C	F	D	G	G1	X			
40	1,7	4,1	5990	12	50	111	105	43	82,5	69	3	5	12	7,9	0,08	0,007
55	2,7	6,2	4610	18	60	142	115	50	104,5	85	3	8	16	12,7	0,09	0,018
70	5,5	12	4130	28	75	168	130	62	130,5	107	3	14	22	21	0,15	0,045
85	8,5	21	3980	40	95	200	150	76	158,5	133	5	12	26	38	0,25	0,118
100	13,5	34	3850	50	110	225	170	90	183,5	152	5	24	38	55	0,45	0,23
120	22	54	3700	60	130	265	185	105	211,5	178	6	27	45	84	0,70	0,505
140	34	83	3200	70	155	300	215	120	245,5	209	6	32	50	134	0,90	1,01
160	43	99	2900	85	170	330	245	135	275	234	8	37	58	180	1,54	1,735
180	68	156	2550	95	190	370	295	150	307	254	8	50	70	260	2,30	3,03
200	82	195	2320	110	210	406	300	175	335	279	8	53	80	317	3,20	4,55
220	150	348	2100	120	230	438	305	190	367	305	8	58	86	382	3,90	6,15
250	195	579	1800	120	280	505	310	220	423	355	10	72	96	546	6,10	12,5
280	275	550	1200	150	325	580		250	495	400	12	-	-	-	6,50	-
320	381	762	980	170	370	630		275	545	450	12	-	-	-	7,20	-
360	492	984	900	190	400	700		305	589	490	12	-	-	-	8,50	-
400	658	1316	800	210	430	760		330	649	550	12	-	-	-	11,40	-
450	835	1670	700	240	475	825		355	714	580	12	-	-	-	12,50	-

(1) I valori si riferiscono a mozzi senza foro - Data with unbored hubs

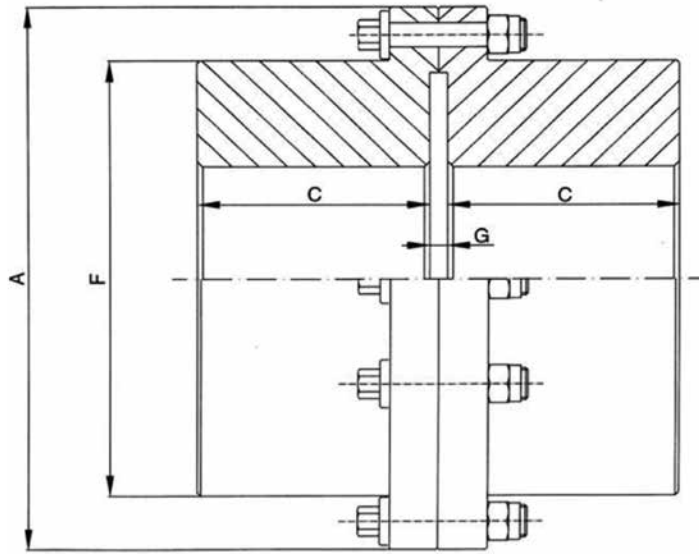

RE...FOO

Taglia Size	Coppia Torque		Velocità Speed	Fori Bores	Dimensioni Dimensions				Peso Weight	Inerzia Inertia
	kNm		Rpm	mm	mm				kG (1)	Kgm ² (1)
	Tn	Tmax	max	min	A	C	F	G		
40	1,7	4,1	5990	60	111	43	82,5	3	5,2	0,005
55	2,7	6,2	4610	75	142	50	104,5	3	9	0,012
70	5,5	12	4130	90	168	62	130,5	3	14,6	0,032
85	8,5	21	3980	110	200	76	158,5	5	28	0,084
100	13,5	34	3850	130	225	90	183,5	5	42	0,162
120	22	54	3700	150	265	105	211,5	6	66	0,375
140	34	83	3200	175	300	120	245,5	6	98	0,728
160	43	99	2900	195	330	135	275	8	137	1,225
180	68	156	2550	220	370	150	307	8	192	2,105
200	82	195	2320	240	406	175	335	8	266	3,401
220	150	348	2100	260	438	190	367	8	345	5,052
250	195	579	1800	300	505	220	423	10	525	10,32
280	275	550	1200	365	580	250	495	12	751	20,60
320	381	762	980	395	630	275	520	12	960	33,50
360	492	984	900	425	700	305	556	12	1230	53,30
400	658	1316	800	470	760	330	615	12	1810	83,50
450	835	1670	700	520	825	355	680	12	2140	128,40

(1) I valori si riferiscono a mozzi senza foro - Data with unbored hubs

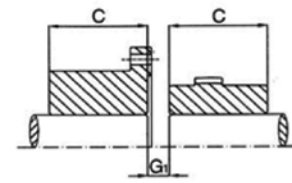
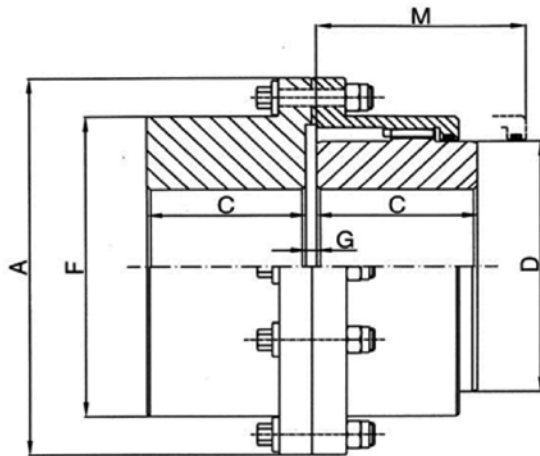

RE...FOR

Con un mozzo rigido e uno rovesciato
With a rigid and a reverse hub



RE...FO

Flangia porta guarnizione dalla taglia 280
Seal flange from size 280

Taglia Size	Coppia Torque		Velocità Speed	Fori Bores			Dimensioni Dimensions							Peso Weight	Grasso Grease	Inerzia Inertia
	kNm		Rpm	mm			mm							kG	kG	Kgm ²
	Tn	Tmax	max	min	max	max(1)	A	C	D	F	M (2)	G	G1	(3)		(3)
40	1,7	4,1	5990	12	50	60	111	43	69	82,5	58	3	5	4,60	0,05	0,005
55	2,7	6,2	4610	18	60	75	142	50	85	105	68	3	8	8,50	0,09	0,014
70	5,5	12	4130	28	75	90	168	62	107	131	87	3	14	13,8	0,15	0,035
85	8,5	21	3980	40	95	110	200	76	133	159	95	5	12	27,0	0,25	0,09
100	13,5	34	3850	50	110	130	225	90	152	184	120	5	24	39,5	0,45	0,18
120	22	54	3700	60	130	150	265	105	178	212	130	6	27	62,5	0,70	0,41
140	34	83	3200	70	155	175	300	120	209	246	135	6	32	94,6	0,90	0,78
160	43	99	2900	85	170	195	330	135	234	275	155	8	37	130	1,54	1,233
180	68	156	2550	95	190	220	370	150	254	307	195	8	40	181	2,30	2,28
200	82	195	2320	110	210	240	406	175	279	335	220	8	53	250	3,20	3,73
220	150	348	2100	120	230	260	438	190	305	367	236	8	58	320	3,90	5,59
250	195	579	1800	120	280	300	505	220	355	423	273	10	72	490	6,10	10,55
280	275	550	1200	150	325	365	580	250	400	495	-	12	-	718	5,20	21,11
320	381	762	980	170	370	395	630	275	450	520	-	12	-	940	5,80	34,50
360	492	984	900	190	400	425	700	305	490	556	-	12	-	1220	8,00	55,10
400	658	1316	800	210	430	470	760	330	550	615	-	12	-	1700	10,00	87,52
450	835	1670	700	240	475	520	825	355	580	680	-	12	-	2100	12,00	131,50

(1) Foro max mozzo rigido - Max bore rigid hub

(2) Distanza minima necessaria per l'allineamento - Minimum clearance required for alignment

(3) I valori si riferiscono a mozzi senza foro - Data with unbored hubs

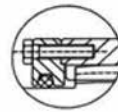
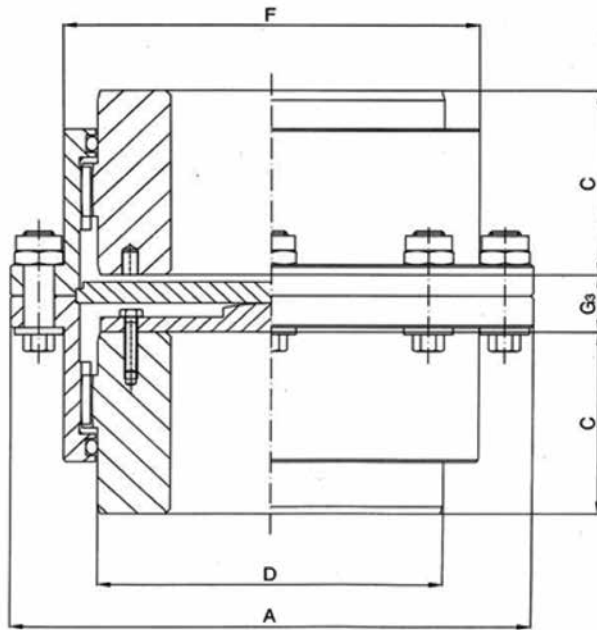

Flangia porta guarnizione dalla taglia 280
Seal flange from size 280

RE...V

Taglia Size	Coppia Torque		Velocità Speed	Fori Bores		Dimensioni Dimensions					Peso Weight	Grasso Grease	Inerzia Inertia
	kNm		Rpm	mm		mm					kG (1)	kG	Kgm ² (1)
	Tn	Tmax	max	min	max	A	C	F	D	G3			
40	1,7	4,1	5990	12	50	111	43	82,5	69	23	5	0,08	0,005
55	2,7	6,2	4610	18	60	142	50	104,5	85	23	9	0,09	0,012
70	5,5	12	4130	28	75	168	62	130,5	107	31	15	0,15	0,032
85	8,5	21	3980	40	95	200	76	158,5	133	31	28	0,25	0,084
100	13,5	34	3850	50	110	225	90	183,5	152	43	49	0,45	0,162
120	22	54	3700	60	130	265	105	211,5	178	48	62	0,70	0,375
140	34	83	3200	70	155	300	120	245,5	209	58	95	0,90	0,728
160	43	99	2900	85	170	330	135	275	234	66	129	1,54	1,225
180	68	156	2550	95	190	370	150	307	254	92	178	2,30	2,105
200	82	195	2320	110	210	406	175	335	279	98	244	3,20	3,401
220	150	348	2100	120	230	438	190	367	305	108	307	3,90	5,052
250	195	579	1800	120	280	505	220	423	355	134	470	6,10	10,32
280	275	550	1200	150	325	580	250	495	400	140	725	6,50	20,60
320	381	762	980	170	370	630	275	545	450	140	970	7,20	33,50
360	492	984	900	190	400	700	305	589	490	140	1260	8,50	53,30
400	658	1316	800	210	430	760	330	649	550	150	1650	11,40	83,50
450	835	1670	700	240	475	825	355	714	580	150	2130	12,50	128,40

(1) I valori si riferiscono a mozzi senza foro - Data with unbored hubs

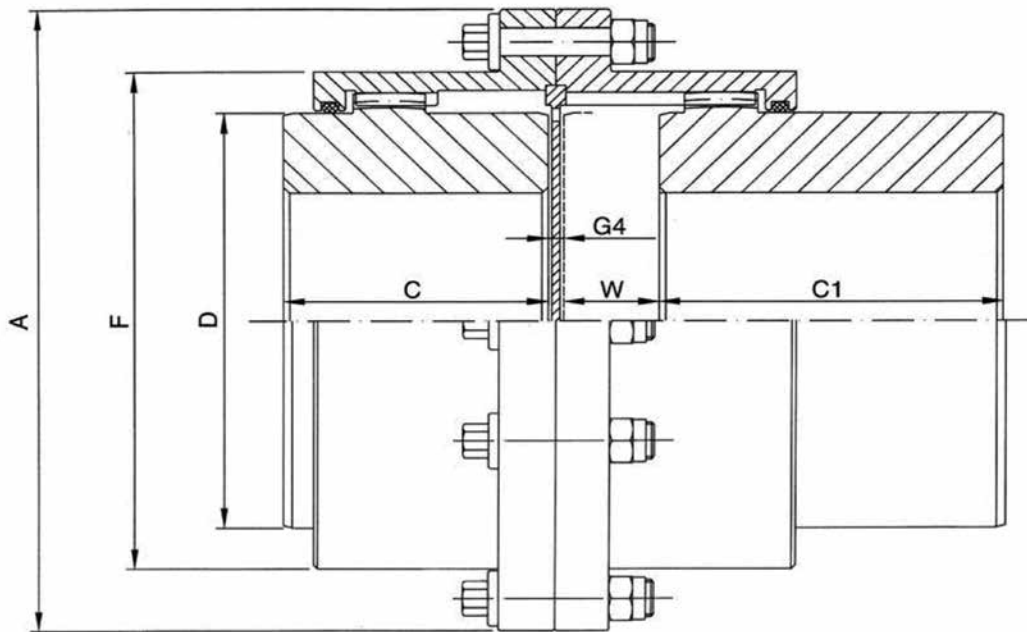

RE...FT

Taglia Size	Coppia Torque		Velocità Speed	Fori Bores		Dimensioni Dimensions							Grasso Grease
	kNm		Rpm	mm		mm							kG
	Tn	Tmax	max	min	max	A	C	F	D	C1	G4	W	
40	1,7	4,1	5990	12	50	111	43	82,5	69	100	7	62	0,08
55	2,7	6,2	4610	18	60	142	50	104,5	85	102	7	62	0,09
70	5,5	12	4130	28	75	168	62	130,5	107	110	7	64	0,15
85	8,5	21	3980	40	95	200	76	158,5	133	122	8	72	0,25
100	13,5	34	3850	50	110	225	90	183,5	152	130	8	72	0,45
120	22	54	3700	60	130	265	105	211,5	178	144	10	80	0,70
140	34	83	3200	70	155	300	120	245,5	209	156	10	88	0,90
160	43	99	2900	85	170	330	135	275	234	162	14	88	1,54
180	68	156	2550	95	190	370	150	307	254	180	14	102	2,30
200	82	195	2320	110	210	406	175	335	279	220	14	130	3,20
220	150	348	2100	120	230	438	190	367	305	220	14	130	3,90
250	195	579	1800	120	280	505	220	423	355	210	16	110	6,10

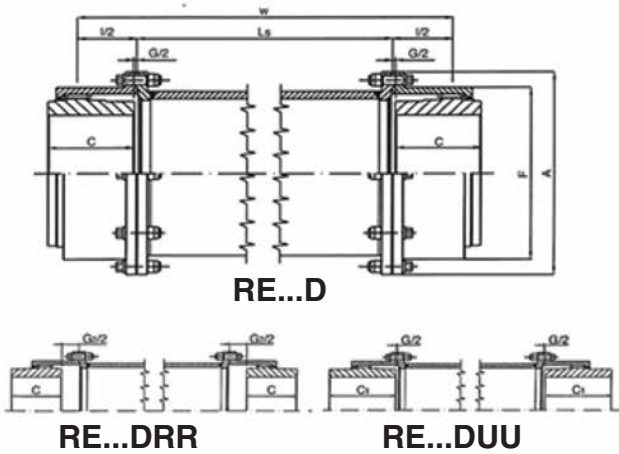

Con mozzi rovesciati
With reverse hubs

Con mozzi allungati
With long hubs



Flangia porta guarnizione dalla taglia 280
Seal flange from size 280



Tabella velocità max. relativa alla W

Esempio di verifica:

Accoppiamento distanziale RE-140 W = 3600 [mm] max 1600 [1/min]

Max speed sheet relative to W

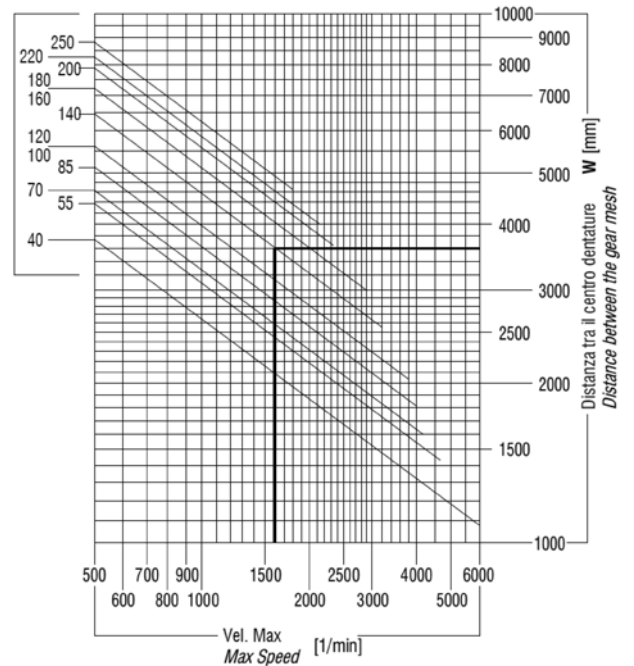
Verification Example:

RE-140 Spacer Coupling W = 3600 [mm] max 1600 [1/min]

Taglia Size	Fori Bores		Dimensioni Dimensions								Grasso Grease
	mm		mm								kg
	min	max	A	C	C1	F	G	G2	I	Ls min	
40	12	50	111	43	105	82,5	3	7	48	80	0,08
55	18	60	142	50	115	104,5	3	13	58	90	0,09
70	28	75	168	62	130	130,5	3	25	76	90	0,15
85	40	95	200	76	150	158,5	5	19	88	100	0,25
100	50	110	225	90	170	183,5	5	43	144	100	0,45
120	60	130	265	105	185	211,5	6	48	132	110	0,70
140	70	155	300	120	215	245,5	6	58	152	110	0,90
160	85	170	330	135	245	275	8	66	172	130	1,54
180	95	190	370	150	295	307	8	92	200	150	2,30
200	110	210	406	175	300	335	8	98	228	160	3,20
220	120	230	438	190	305	367	8	108	248	170	3,90
250	120	280	505	220	310	423	10	134	292	180	6,10
280	150	325	580	250	-	495	12	-	-	-	6,50
320	170	370	630	275	-	545	12	-	-	-	7,20
360	190	400	700	305	-	589	12	-	-	-	8,50
400	210	430	760	330	-	649	12	-	-	-	11,40
450	240	475	825	355	-	714	12	-	-	-	12,50

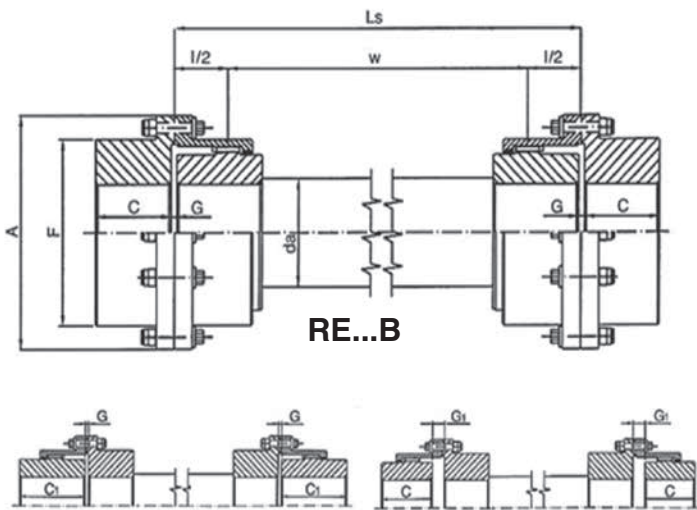

RE...CUU

Con mozzi allungati
With long hubs

RE...CRR

Con mozzi rovesciati
With reverse hubs



Flangia porta guarnizione dalla taglia 280
Seal flange from size 280



Tabella velocità max. relativa alla W

Esempio di verifica:

Accoppiamento distanziale RE-140 W = 3600 [mm] max 1600 [1/min]

Max speed sheet relative to W

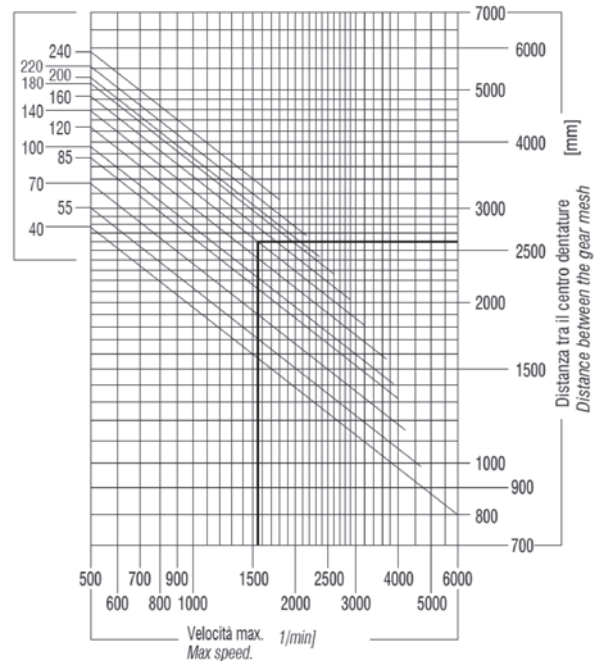
Verification Example:

RE-140 Spacer Coupling W = 3600 [mm] max 1600 [1/min]

Taglia Size	Fori Bores			Dimensioni Dimensions								Grasso Grease
	mm			mm								kG
	min	max	max (1)	A	C	C1	F	da	G	G1	I	
40	12	50	60	111	43	105	82,5	55	3	5	48	0,08
55	18	60	75	142	50	115	104,5	65	3	8	58	0,09
70	28	75	90	168	62	130	130,5	80	3	14	76	0,15
85	40	95	110	200	76	150	158,5	100	5	12	88	0,25
100	50	110	130	225	90	170	183,5	110	5	24	144	0,45
120	60	130	150	265	105	185	211,5	130	6	27	132	0,70
140	70	155	175	300	120	215	245,5	150	6	32	152	0,90
160	85	170	195	330	135	245	275	170	8	37	172	1,54
180	95	190	220	370	150	295	307	190	8	50	200	2,30
200	110	210	240	406	175	300	335	200	8	53	228	3,20
220	120	230	260	438	190	305	367	220	8	58	248	3,90
250	120	280	300	505	220	310	423	250	10	72	292	6,10
280	150	325	365	580	250	-	495	-	12	-	-	6,50
320	170	370	395	630	275	-	545	-	12	-	-	7,20
360	190	400	425	700	305	-	589	-	12	-	-	8,50
400	210	430	470	760	330	-	649	-	12	-	-	11,40
450	240	475	520	825	355	-	714	-	12	-	-	12,50

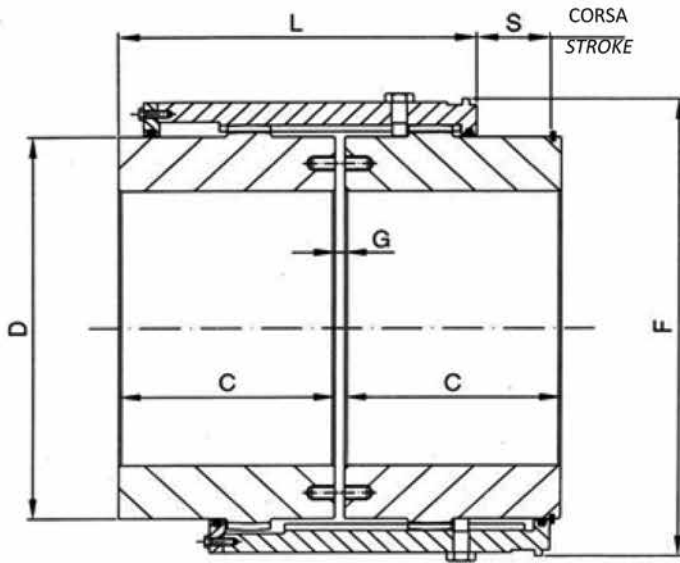

RE...DH MN

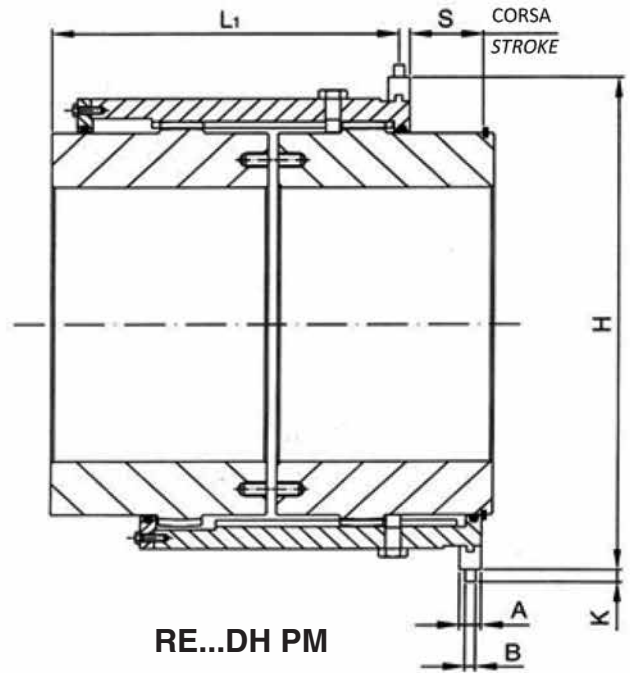

RE...DH PM

Taglia Size	Coppia Torque		Velocità Speed	Fori Bores		Dimensioni Dimensions										Grasso Grease
	kNm		Rpm	mm		mm										kG
	Tn	Tmax	max	min	max	F	C	D	L	G	S	A	B	K	H	
40	1,7	4,1	5990	12	50	100	60	69	100	3	17	20	12	12	10	0,07
55	2,7	6,2	4610	18	60	120	70	85	110	3	18	20	12	12	150	0,08
70	5,5	12	4130	28	75	152	85	107	140	3	29	24	16	16	190	0,10
85	8,5	21	3980	40	95	176	95	133	155	5	32	24	16	16	210	0,20
100	13,5	34	3850	50	110	200	105	152	170	5	34	24	16	16	240	0,40
120	22	54	3700	60	130	230	120	178	195	6	39	32	20	20	270	0,60
140	34	83	3200	70	155	260	130	209	205	6	45	32	20	20	310	0,80
160	43	99	2900	85	170	190	150	234	240	8	50	32	20	20	330	1,50
180	68	156	2550	95	190	320	175	254	280	8	56	32	20	20	360	2,00
200	82	195	2320	110	210	250	190	279	300	8	62	40	24	22	400	3,00
220	150	348	2100	120	230	395	220	305	350	8	70	40	24	22	450	3,50
250	195	579	1800	120	280	450	250	355	400	10	77	50	28	24	510	4,00
280	275	550	1200	150	325	545	275	400	430	12	80	50	28	24	610	4,50
320	381	762	980	170	370	590	300	450	470	12	87	60	32	30	660	5,50
360	492	984	900	190	400	640	335	490	510	12	95	60	32	30	710	6,00
400	658	1316	800	210	430	715	360	550	560	12	100	80	44	40	810	7,00
450	835	1670	700	240	475	780	390	580	600	12	110	80	44	40	870	9,50

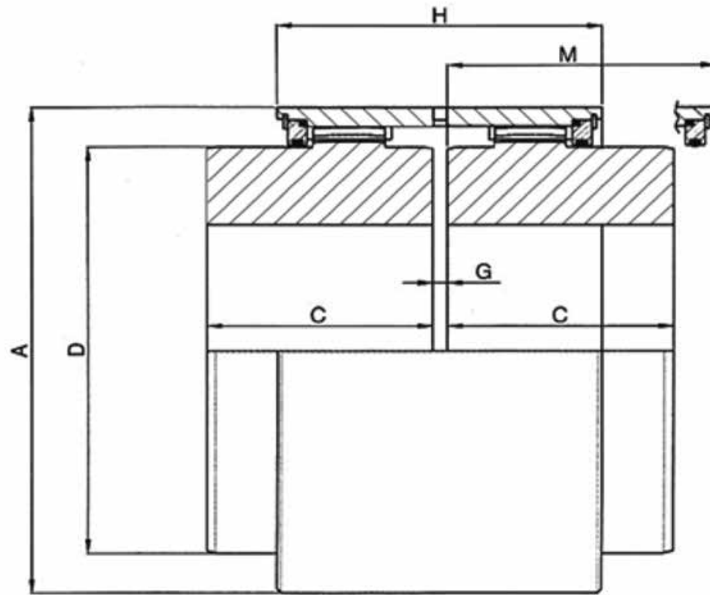

RE...M



Flangia porta guarnizione dalla taglia 280
Seal flange from size 280

Taglia Size	Coppia Torque		Velocità Speed	Fori Bores		Dimensioni Dimensions					Peso Weight	Grasso Grease	Inerzia Inertia
	kNm		Rpm	mm		mm					kG (2)	kG	Kgm ² (2)
	Tn	Tmax	max	min	max	A	C	D	M(1)	G			
40	1,7	4,1	5990	12	50	98	43	69	91	3	4	0,07	0,005
55	2,7	6,2	4610	18	60	115	50	85	102	3	8	0,08	0,011
70	5,5	12	4130	28	75	145	62	107	117	3	12,5	0,10	0,031
85	8,5	21	3980	40	95	176	76	133	146	5	25	0,20	0,082
100	13,5	34	3850	50	110	196	90	152	150	5	34	0,40	0,15
120	22	54	3700	60	130	225	105	178	169	6	58	0,60	0,325
140	34	83	3200	70	155	256	120	209	185	6	86	0,80	0,685
160	43	99	2900	85	170	286	135	234	203	8	118	1,50	1,125
180	68	156	2550	95	190	310	150	254	200	8	155	2,00	1,724
200	82	195	2320	110	210	345	175	279	225	8	225	3,00	2,802
220	150	348	2100	120	230	375	190	305	240	8	270	3,50	4,542
250	195	579	1800	120	280	430	220	355	270	10	404	4,00	8,42
280	275	550	1200	150	325	495	250	400	305	12	590	4,50	15,73
320	381	762	980	170	370	545	275	450	340	12	785	5,50	24,82
360	492	984	900	190	400	590	305	490	350	12	980	6,00	35,66
400	658	1316	800	210	430	650	330	550	360	12	1395	7,00	58,72
450	835	1670	700	240	475	715	355	580	70	12	1790	9,50	95,42

(1) Distanza minima necessaria per l'allineamento - *Minimum clearance required for alignment*

(2) I valori si riferiscono a mozzi senza foro - *Data with unbored hubs*

I giunti a denti ROTOGEAR sono imballati e spediti senza lubrificante.

I giunti vengono forniti con uno speciale protettivo resistente alla corrosione. Per quanto riguarda l'assemblaggio e la manutenzione preghiamo di seguire attentamente le istruzioni che seguono. Tali istruzioni si applicano generalmente per una lubrificazione a grasso.

Per l'assemblaggio non sono richiesti speciali attrezzi.

1. Montaggio

- 1.1 prima di assemblare verificare che esista il minimo spazio disponibile tra le macchine secondo quanto indicato nelle tabelle. Verificare che il giunto venga installato con mozzi in posizione normale o in configurazione rovesciata.
- 1.2 smontare il giunto e pulire adeguatamente tutte le superfici.
- 1.3 posizionare la linguetta nell'apposita sede sull'albero. Inserire l'anello O-ring di tenuta nella sede della campana esterna e infilare quest'ultima sull'albero; per le grandezze a partire da 590 ed oltre inserire l'anello O-ring nel piattello di chiusura, inserire il mozzo sull'albero facendo attenzione a non danneggiare l'O-ring. Ripetere la stessa procedura con l'altro semigiunto. L'uso di una emulsione a base di molikote potrà essere di beneficio per il montaggio del mozzo.
- 1.4 per montaggio con interferenza, gli anelli O-ring od i piattelli di chiusura dovranno essere adeguatamente protetti mentre si riscalda il mozzo. Qualora sia stato previsto l'impiego di un giunto con dentatura trattata, è importante che la temperatura del mozzo non ecceda i 200°C.
- 1.5 una volta terminate le operazioni di assemblaggio dei mozzi verificare l'allineamento e la quota E, la quale dovrà rispettare il valore riportato a catalogo con una tolleranza compresa entro i 0,5 mm (assiali). Verificare con cura l'allineamento degli alberi.
- 1.6 applicare del mastice sulle superfici d'unione delle flange dentate del giunto, per le misure da 590 ed oltre applicare lo stesso sulle superfici di contatto dei piattelli di chiusura; quindi inserire i bulloni e completare l'assemblaggio del giunto. Avere cura di posizionare i fori di lubrificazione presenti sulle campane dentate con spostamento di 90°.
- 1.7 una volta completato l'assemblaggio provvedere ad immettere nel giunto la corretta quantità di lubrificante.
- 1.8 verificare che il giunto abbia possibilità di movimento angolare ed assiale. N.B.: le norme anti infortunistiche (d.p.r. 27.04.75 nr.457 art. 55) prevedono ripari fissi su parti rotanti.

2. Manutenzione

- 2.1 sostituire completamente il lubrificante (grasso) ogni 8.000 ore di funzionamento avendo cura di effettuare una radicale pulizia del giunto ed un controllo dell'allineamento degli alberi.
- 2.2 per temperature ambiente da -10°C a +90°C, usare grassi con caratteristiche EP ed additivi al litio. A titolo puramente informativo elenchiamo i seguenti lubrificanti da noi consigliati (a condizioni ambientali e di funzionamento standard):

AGIP: GR-MU/EPO (EP1)
MOBIL: MOBILGREASE-SPECIAL

SHELL: ALVANIA EP GREASE 1
IP: ATHESIA-EPO

API: APIGREASE PGX-0
ESSO: PEN-O-LED-EP 350

- 2.3 ogni 5-7 mesi aggiungere nuovo grasso se necessario, e controllare il libero movimento assiale delle flange dentate.
- 2.4 in caso di perdita di lubrificante dalle flange dentate, occorre disaccoppiare il giunto, pulire le superfici di unione, applicare nuovo mastice e procedere al nuovo riempimento. Per temperature d'esercizio elevate contattare il nostro Ufficio Tecnico per la scelta del lubrificante più idoneo.

RE gear couplings are packed and delivered without lubrication. Couplings are supplied with a special corrosion-proof protective grease. You are required to follow the instructions below to assure correct assembly and maintenance.

These instructions assume a grease lubrication.

Special tools are not required for the assembly.

1 Assembly Instruction

- 1.1 Check that the minimum space required for assembly is available between the machines as shown on the tables. Verify that the coupling is installed with the hubs in normal or in reversed position.
- 1.2 Disassemble the coupling and clean all the surfaces.
- 1.3 Position the key in the suitable keyseat on the shaft. Insert the O-ring in the seat of the external sleeve and install it on the shaft; for sizes starting from 590 insert the O-ring in the cover plate, insert the hub on the shaft being careful to not damage the O-ring. Do the same with the other half coupling. Use of a molikote based grease can be useful for hub assembly.
- 1.4 For assembly with an interference fit, O-rings or cover plates must be adequately protected during the hub warming up. In case of assembling a coupling with heat treated teeth, is important that the hub temperature is not higher than 200°C.
- 1.5 With the hubs assembled on the shafts, check that the alignment and dimension "S" is according to the dimensional tables with a tolerance of 0.5 mm (axial). Check the shaft alignment carefully.
- 1.6 Apply some joint adhesive on the mating surfaces of the toothed sleeves of the coupling. For sizes starting from 590 joint adhesive must be applied on contact surfaces of the closing plates. Then insert the bolts and complete the assembly of the coupling. Position the lubrication holes on the toothed sleeves offset by 90°.
- 1.7 Fill the coupling with the right quantity of grease when the assembly is completed.
- 1.8 Check that the coupling has angular and axial movement. Note: accident prevention rules (d.p.r. 27.04.75 nr. 457 art. 55) require fixed guard on rotating parts.

2. Maintenance

- 2.1 Completely replace the grease every 8000 hours of operation, by carefully cleaning the coupling and checking the shaft alignment. 2.2 For ambient temperature from -10°C to +90°C, use of a grease with EP features and lithium-based additive is required. We suggest the use of the following lubricants (with standard ambient and operating conditions):

2.3 Add new grease every 5-6 months if necessary and check the free axial movement of the toothed sleeves.

2.4 In case of grease leakage from the toothed sleeves, disassemble the coupling, clean the mating surfaces, apply new joint adhesive and fill the coupling with new grease. For high service temperatures contact our technical dept. for the choice of the proper lubricant.

WESTCAR NEL MONDO WESTCAR WORLDWIDE



Albania	Colombia	Gran Bretagna	Olanda	Serbia
Australia	Corea	Grecia	Pakistan	Singapore
Belgio	Croazia	Iran	Perù	Slovenia
Bielorussia	Danimarca	Lettonia	Polonia	Spagna
Bosnia & Erzegovina	Egitto	Lituania	Portogallo	Sud Africa
Brasile	Estonia	Macedonia	Rep. Ceca	Svezia
Canada	Finlandia	Marocco	Rep. Slovacca	Thailandia
Cile	Francia	Norvegia	Romania	Turchia
Cina	Germania	Nuova Zelanda	Russia	USA

<i>Albania</i>	<i>Colombia</i>	<i>Great Britain</i>	<i>New Zealand</i>	<i>Singapore</i>
<i>Australia</i>	<i>Croatia</i>	<i>Greece</i>	<i>Norway</i>	<i>Slovak Republic</i>
<i>Belarus</i>	<i>Czech Republic</i>	<i>Holland</i>	<i>Pakistan</i>	<i>Slovenia</i>
<i>Belgium</i>	<i>Denmark</i>	<i>Iran</i>	<i>Peru</i>	<i>South Africa</i>
<i>Bosnia and Herzegovina</i>	<i>Egypt</i>	<i>Korea</i>	<i>Poland</i>	<i>Spain</i>
<i>Brazil</i>	<i>Estonia</i>	<i>Latvia</i>	<i>Portugal</i>	<i>Sweden</i>
<i>Canada</i>	<i>Finland</i>	<i>Lithuania</i>	<i>Romania</i>	<i>Thailand</i>
<i>Chile</i>	<i>France</i>	<i>Macedonia</i>	<i>Russia</i>	<i>Turkey</i>
<i>China</i>	<i>Germany</i>	<i>Morocco</i>	<i>Serbia</i>	<i>USA</i>

Distributore *Distributor*



WESTCAR s.r.l.

Sede Legale e Uffici - Headquarter

Via Monte Rosa, 14 - 20149 Milano (ITALY)

Tel. +39 02 761 10 319 - Fax +39 02 761 10 041

Sede Produttiva - Production Plant

Via Venezia, 31 - 21058 Solbiate Olona (VA - ITALY)

info@westcar.it - www.westcar.it